

# Countstar Castor High-Throughput Cell Analyzer

High Content Screening of Cells and Organoids



# Overview

The Countstar Castor high-throughput cell analyzers provide high content screening (HCS) solutions to a wide variety of urgent challenges in life science research, drug development, and cell-based therapies. The integration of advanced scanning technology and AI-powered image processing algorithms enables high-throughput analyses of both 2D cell cultures and 3D organoid cultures with unparalleled speed and accuracy. The comprehensive suite of workflow solutions simplifies operation while providing the flexibility to customize and expand the scope of applications to meet new challenges.

## Traditional 2D Cell Culture Workflows

- Monoclonality assurance assay of suspension or adherent cells
- B-cell cluster identification for antibody discovery
- Confluence analysis
- Cell phenotyping
- GFP/RFP transfection efficiency assay
- Virus plaque assays
- Direct cell counting and viability measurement

## 3D Organoid Workflows

- Organoid growth monitoring and quality control
- Organoid fluorescence viability analysis
- Therapeutic efficacy and cytotoxicity assessment

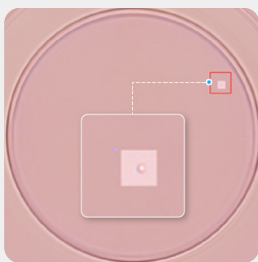

Monoclonality Assay

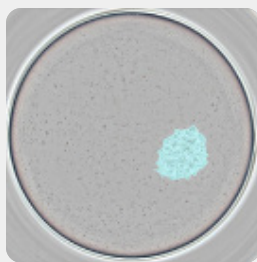

B-Cell Cluster Identification

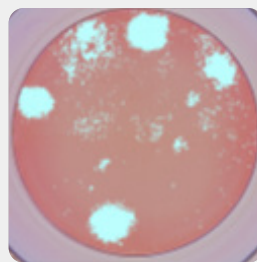

Confluence Assay

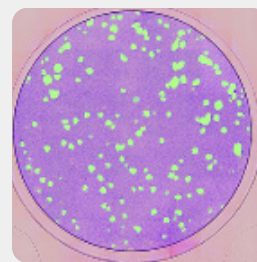

Viral Plaque Counting

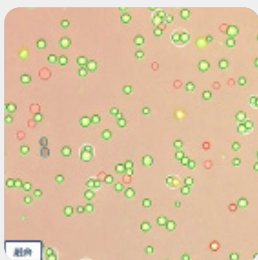

Cell Counting and Viability Assay

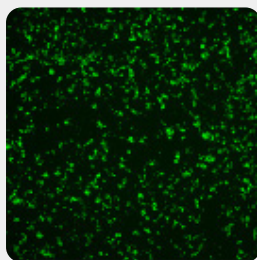

GFP Transfection Assay

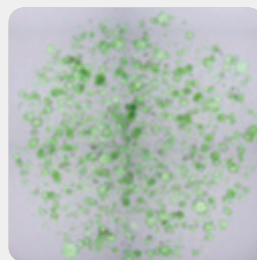

Organoid QC

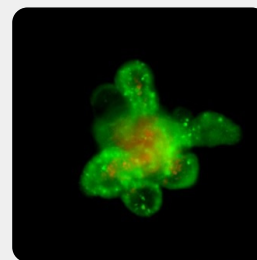

Organoid Viability Assay

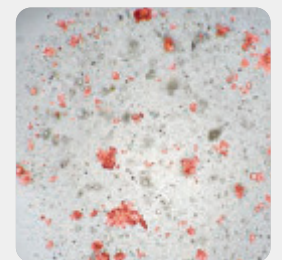

Therapeutic Efficacy and Cytotoxicity Assessment

# Innovative Hardware

## Fast Laser-Ranging Auto-Focusing

Differences in focal planes of single wells on a microtiter plate, either due to the specific design or due to variations in production batches, lead to inconsistent image qualities. The Countstar Castor scans each well bottom with a laser to determine the optimum focus in milli-seconds, thus ensuring clear images of each well. The laser ranging auto-focusing also allows the usage of multi-well plates from a wide range of suppliers.

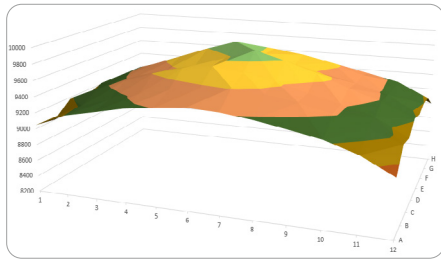

3D diagram of a 96-well plates, showing the variations in well bottom heights

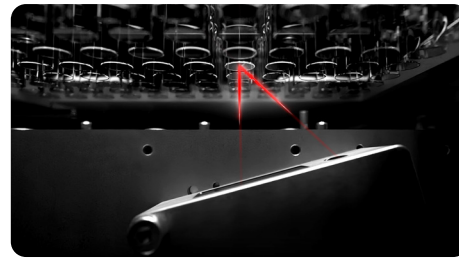

Laser ranging of well bottoms to identify the optimal focal length of each well

## Innovative Concave Meniscus Illumination

The concave meniscus formed in the wells of a microtiter plate causes significant light refraction near the edge of a well, resulting in an image with dark ring section when using common imaging technology. This makes it challenging to identify and quantify cells seeded near the edge. Using innovative illumination and imaging technology, the Countstar Castor is able to capture bright and clear images of the entire well area, enabling confident identification of single cells near the edge of a well.

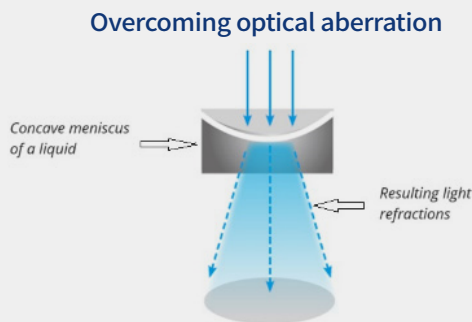

Traditional optics  
Dark well edge



Castor Technology  
Bright image

## Full Automation for Maximum Throughput

The Countstar Castor contains all the necessary components, interfaces, and software modules to be integrated into various automated platforms, from simple multi-axis robotic arm with plate stackers to fully automated station with sample preparation and liquid handling stations. Built-in barcode readers guarantee secure and traceable identification of each sample carrier.

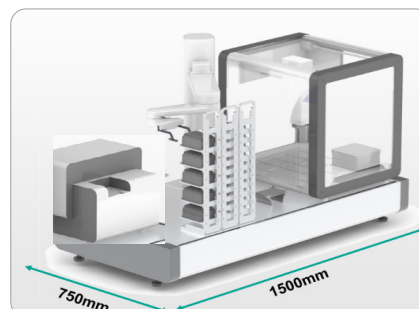

# Innovative Hardware

## Ultrafast Z-axis Scanning for 3D Imaging

The ultrafast Z-axis scanning function addresses a major challenge in high-throughput 3D image acquisition. Clear 2D images are captured along the Z axis at ultra-high speed, dramatically reducing the image acquisition time. It takes only 4min to complete image acquisition for a 96-well plate when ten 2D images are acquired per well. The linked images of each well are projected to construct a 2D image where cells or organoids at different focal lengths are shown in focus, enabling a comprehensive analysis of each organoid's phenotype characteristics or confident identification of single cells in monoclonality assay.

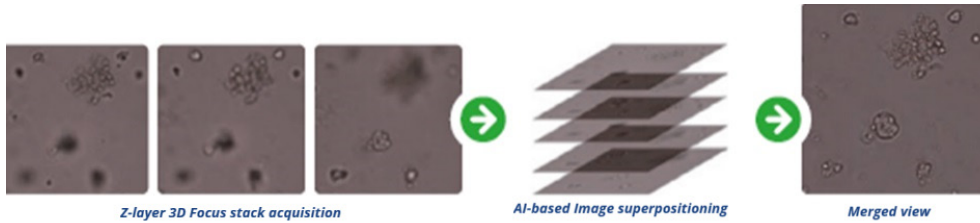

## High-Sensitivity CMOS Camera & Three Fluorescence Channels (Blue/Green/Red)

Each Countstar Castor is equipped with a high-sensitivity, Peltier-cooled CMOS camera with a resolution of 10MP and three fluorescence channels (Blue/Green/Red). The 4x and 10x objectives of high numerical aperture (NA) captures high-resolution images which enables precise phenotyping of cells and organoids. The three fluorescence channels allow for a wide range of applications using all common fluorophores labeling whole cells or even sub-cellular compartments.

Excitation (EX) wavelength (nm)	Emission (EM) wavelength (nm)	Frequently used fluorescent dyes
395/15	460/20	DAPI/Hochest
480/30	535/40	FITC / GFP / Calcein AM / CFSE / Alexa Fluor488
545/15	590/25	RFP / PI/ Texas Red / TRITC / PE

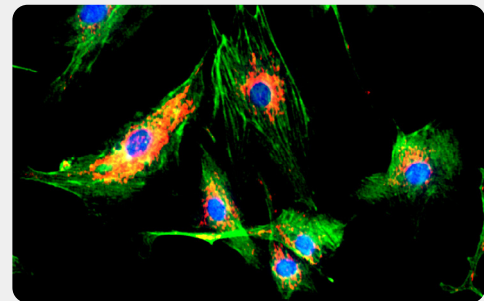

Triple stained heart muscle cells, acquired at 10x in a 24 well plate on a Countstar Castor

## Flexible Consumable Design

The pre-installed consumable library contains the design data of a wide range of consumables from various suppliers. New consumables can be easily added to the library by the user.

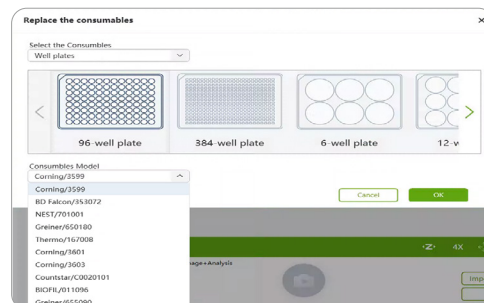

# Intelligent Software

## Artificial Intelligence (AI) Powered Image Processing and Analysis

Using AI-powered image recognition and analysis algorithms, the Countstar Castor can accurately and efficiently identify target cells or organoids from complex matrix background and obtain comprehensive quantitative information. Application-based workflows (BioApps) were developed using the process described in the figure below. The algorithm for each BioApp is optimized through multiple rounds of training to ensure accurate identification and characterization of target cells and organoids. New algorithms can be quickly developed to expand the scope of applications.

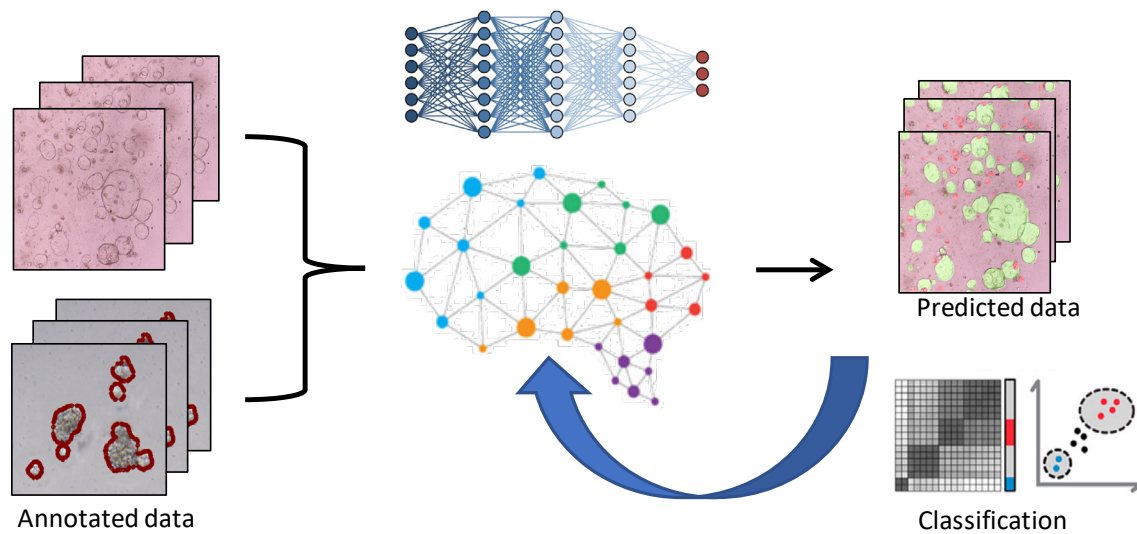

The AI-powered algorithms are particularly important for highly heterogeneous samples, such as organoids or co-cultured cells. Organoids are 3D structures with dramatically different sizes and shapes. It is impossible to obtain accurate identification using traditional image process method. Using the AI-powered algorithms, Countstar Castor can achieve >85% accuracy in organoid identification and classification, while generating quantitative information on a comprehensive set of phenotypic characteristics.

### Various organoid morphologies precisely detected by the AI based analysis algorithms

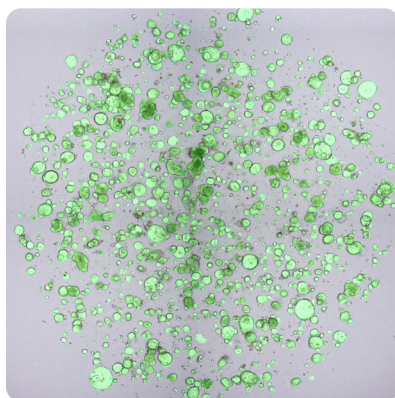

Colorectal cancer organoids

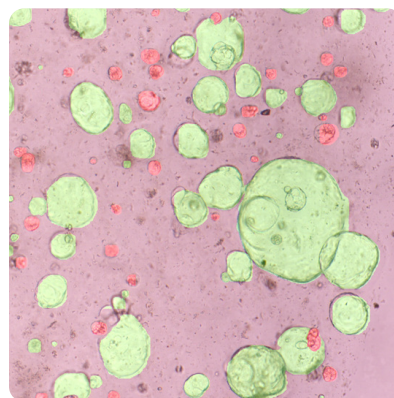

Hepatic cancer organoids

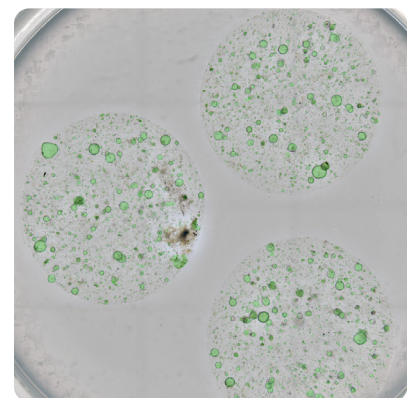

Gastric cancer organoids

# Intelligent Software

## Intuitive Graphical User Interface

The application-based user interface dramatically simplifies routine operation and allows easy expansion of application scope. A comprehensive suite of BioApps are pre-installed with optimized parameters for all common applications. Those BioApps can be duplicated or customized to meet the application needs of individual users. New BioApps can be quickly developed through collaboration and added to user interface.

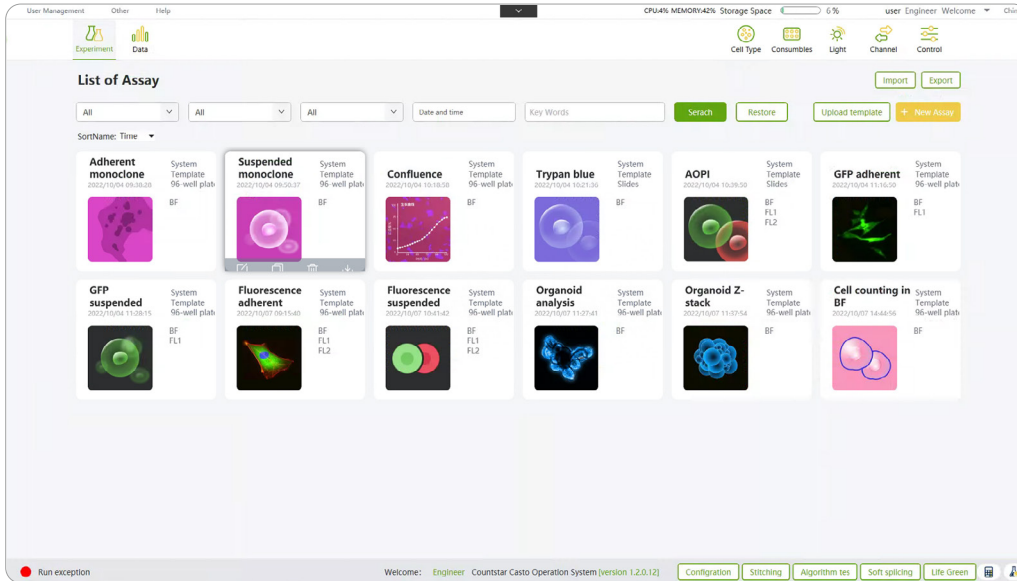

A wide range of data review tools are available to inspect images and analysis results. The results can be displayed as heat maps, scatter plots, time course diagram, or distribution histograms. Data, including raw images, labeled images, and analysis results, can be exported and archived in various formats, including PDF reports and csv summary.

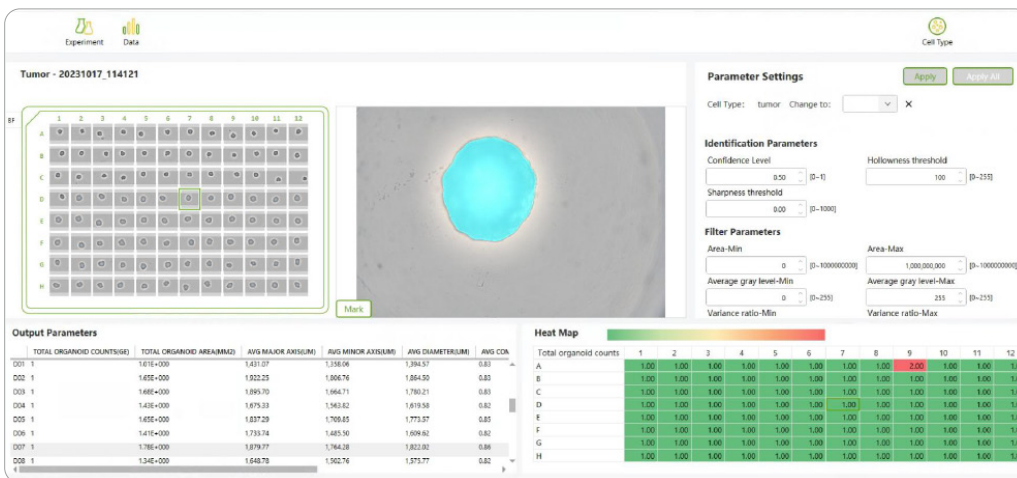

Result view of organoid analysis in a 96-well plate

## cGxP Compliance

Powerful data management and control capabilities make the Countstar Castor fully compliant with FDA 21 CFR Part 11 regulations.

# High-Throughput Organoid Analysis

## Artificial Intelligence (AI), A Game Changer for The Organoid Analysis

Organoids are complex 3D structures that can function similarly to in vivo organs. They are powerful models to advance biology research and accelerate drug development. Unlike classical 2D cell cultures, organoids grown in 3D culture are highly heterogenous in size and shape. In addition, organoids derived from different tissues have dramatically different structures. It is challenging and time-consuming to obtain accurate characterization of organoids using traditional imaging solution. New imaging and data analysis solutions are required to meet the needs of high-throughput organoid-based applications, such as drug efficacy screening and toxicology testing.

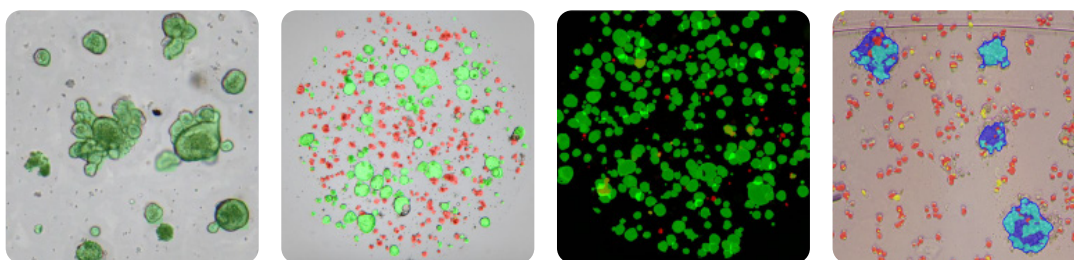

Organoids of different origins (from left to right): Mouse intestinal cells, gastric cancer cells, gastric cancer cells (fluorescence), hepatic cancer cells (with NK cells).

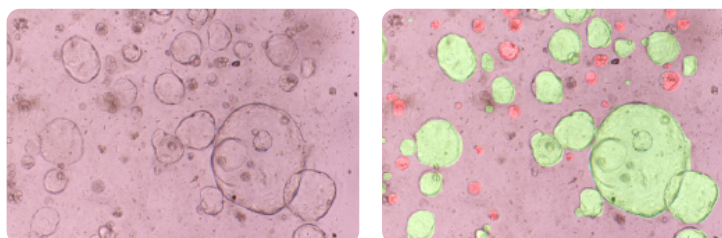

Healthy hepatobiliary-derived organoids, labeled in green, display a vacuole-like structure surrounded by a single layer of epithelial cells. The co-cultivated hepatocyte-cholangiocarcinoma organoids, labeled in red, possess irregular cystic shapes and parenchymal structures.

Using novel z-stack scanning technology and AI-powered imaging processing algorithms, the Countstar Castor can dramatically reduce the 3D image acquisition time and improve the identification accuracy.

- The novel Z-stack scanning function enables the acquisition of multiple clear 2D images along the Z axis at ultra-high speed. It takes only **4min**, rather than hours with traditional imaging method, to complete image acquisition for a 96-well plate when ten 2D images are acquired per well. The fast acquisition makes it possible to conduct large-scale study, also limits the exposure of organoids to culture environment change.
- Different from conventional con-focal 3D imaging, the 2D images of each well acquired at distinct z values are projected to construct a 2D image where cells or organoids at different focal lengths are shown in focus. The constructed 2D images are analyzed using AI-powered algorithms in BioApps, developed for each type of organoids.
- Organoids are identified with **high accuracy (>85%)** and characterized to generate a comprehensive set of phenotypical values, including organoid counts, viability, total area, average diameter, average length of long and short axis, roundness, roughness, hollowness, eccentricity, and relative fluorescence intensity, at both individual level and sample level.

# High-Throughput Organoid Analysis

The Countstar Castor support a broad range of organoid applications from simple quality control to complex drug efficacy screening using co-culture.

## Organoid Growth Monitoring and Quality Control

It is essential to monitor the organoid status after the cells are seeded into a well plate. It takes hours to analyze a 96-well plate with manual image acquisition and data processing. The Countstar Castor simplifies this routine task with ultrafast z-stack image acquisition and automated data processing. It takes only 4 min to complete image acquisition and 15min to complete image processing and quantitative data analysis for a 96-well plate, saving over 80% of time and labor than manual operation. When coupled with an automated plate-loading platform, up to forty eight 96-well plates can be screened per day. Data over the culture duration are automatically organized to generate growth curves.

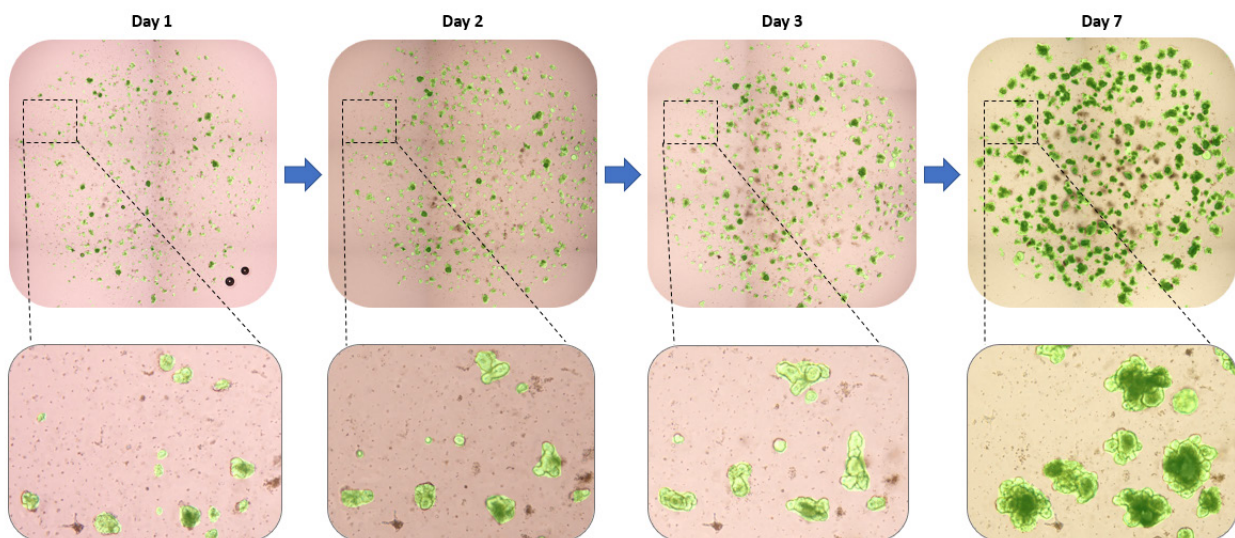

Mouse intestinal organoids were cultured over 7 days, images acquired by a Countstar Castor at Day 1/2/3/7 in bright field. Organoids detected by the AI software are labeled in green.

Output Parameter							
ID	Total No.	Average Major Axis	Average Circularity	Average Minor Axis	Profile Roughness	Hollowness	Eccentricity
A01	13.00	39.81	1.00	37.59	31.22	1.00	0.43
A10	37.00	75.56	0.91	69.86	30.23	1.00	0.43
A11	14.00	62.34	0.94	57.29	25.40	1.00	0.50
A12	13.00	59.28	0.94	53.71	27.40	1.00	0.50
A02	8.00	56.00	0.96	53.05	43.52	1.00	0.40
A03	10.00	28.97	1.01	26.81	30.84	1.00	0.44
A04	11.00	71.17	0.96	67.49	35.44	1.00	0.40
A05	14.00	67.44	0.90	61.61	27.62	1.00	0.45

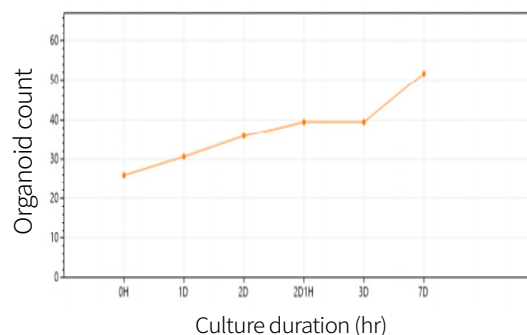

# High-Throughput Organoid Analysis

## Organoid Fluorescence Viability Analysis

Organoid viability is important information in evaluating sample quality, drug efficacy, or drug toxicity, can be measured using Acridine Orange (AO) and Propidium Iodide (PI) staining on the Counstar Castor. High-resolution fluorescent 2D projection images are generated to provide information on spatial localization of dead and live cells in each organoid, while high-resolution bright-field 2D projection images are generated to obtain other phenotypical characteristics, such as organoid counts, average diameter, and organoid area.

mouse small Intestinal organoids

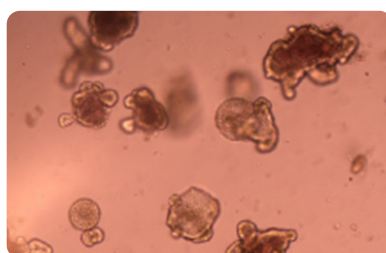

Bright-field image

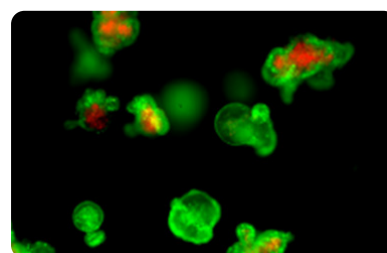

Fluorescence Image  
Viable cells (green); Dead cells (red)

## Label-free Therapeutic Efficacy and Cytotoxicity Assessment

Countstar Castor enables non-invasive monitoring of organoid status during drug treatment. The phenotypical progression of individual organoid can be traced throughout the treatment period, providing insight on drug efficacy or drug toxicity. Patient-derived tumor organoids (PDTO) are the ideal model for evaluating the efficacy of potential therapeutics and predicting a patient's response to a planned therapy. The Countstar Castor enables high-throughput imaging and data processing of complex PDO samples, accelerates the identification of personalized treatment, and allows the doctor to bring life-saving treatments to patients faster.

### Cisplatin

Day 0

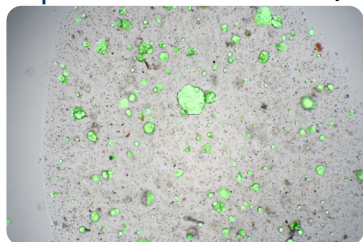

Day 3

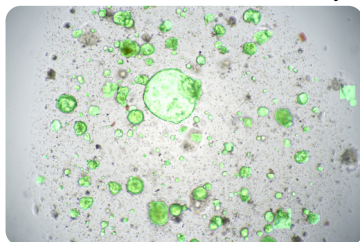

Gastric cancer PDTOs were treated with cisplatin or gemcitabine for three days. Bright-field images were acquired, and organoids were identified and marked in green (live) or red (dead). It is clear that gemcitabine induced broad organoid death while cisplatin did not inhibit the growth of organoids after 3 days of treatment.

### Gemcitabine

Day 0

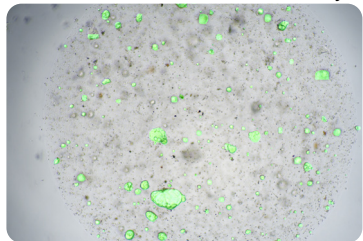

Day 3

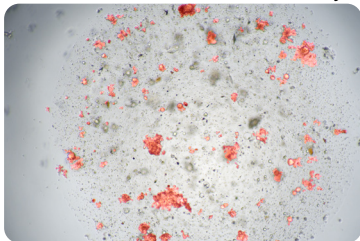

Live cancer PDTOs were co-cultivated with tumor infiltrating lymphocytes (TIL) NK-92MI. Both bright-field and fluorescent images were acquired, organoids were identified and marked in blue (live) or green (dead), red-dead, NK cells are marked in red.

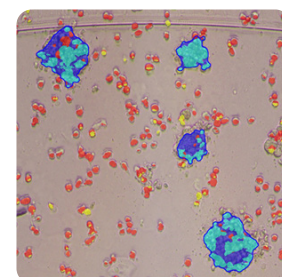

Countstar Castor can also analyze co-cultured samples where organoids were treated with immune cells. Using AI-powered imaging processing algorithms, both organoids and cell can be distinguished and accurately labeled.

# High-Throughput Cell Culture Analysis

Countstar Castor provides novel solutions that significantly improve the accuracy and efficiency for a broad range of high-throughput applications using traditional 2D cell culture. The unique z-stack imaging technology eliminates background interference and ghost well, enables confident identification of single cells in mono-clonality assay. AI-powered algorithms ensure accurate identification of target cells and fast data processing, reduce manual data verification by up to 80%. The Countstar Castor is the ideal platform to accelerate the discovery and development of monoclonal antibodies, cell and gene therapies, virus, cultured meat.

## Monoclonality Assay

It is critical to ensure the monoclonality of cell lines in the development of monoclonal antibody, gene and cell therapies. The Countstar Castor offers a novel approach to accurately and quickly verify if a single cell is seeded into each well, eliminating false positives and ghost wells.

During the initial culture period (Day 0 to Day 2), the plate is imaged using the unique Z stacking image acquisition method. The projected 2D images enable confident identification of cells from background impurities to eliminate false positives, also ensures that cells at different depth, such as the edge of a well, are captured to eliminate ghost wells (false negatives). At the same time, this significantly reduces manual verification time.

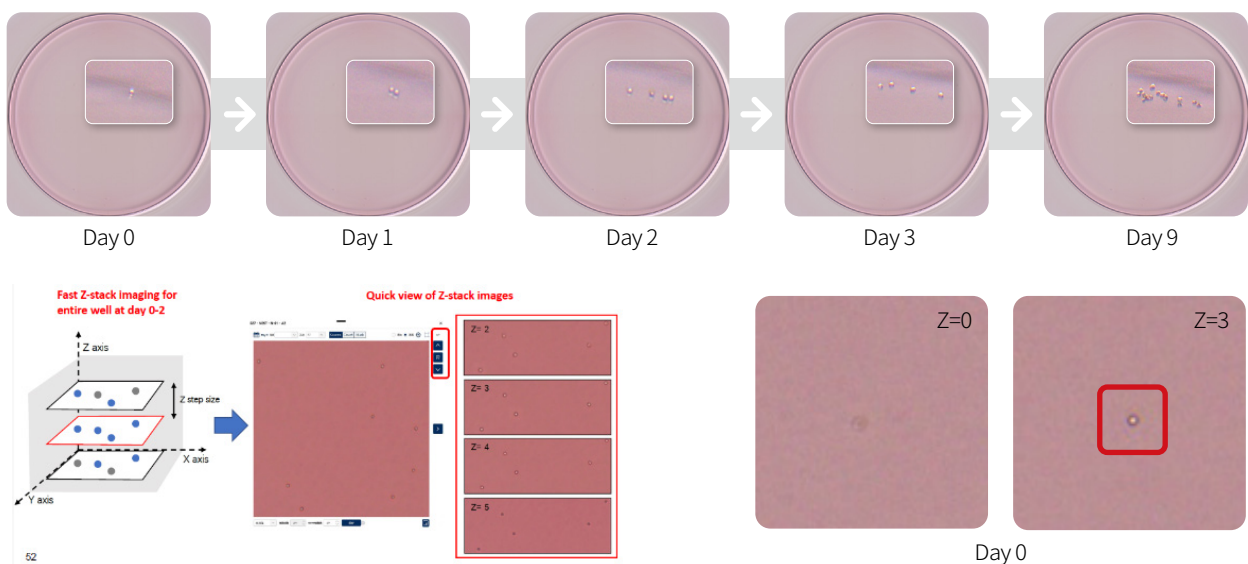

Using AI-powered software, image data are automatically processed and organized to identify the monoclonality of each sample. The results are displayed in multiple formats, including plate view and heat-map view, for easy review. Users can easily review raw images, marked images, growth curves to verify the result or make edits. With the traditional limited dilution method, the Countstar Castor can reduce experiment time by 50% and data verification time by 60-80%, while providing more accurate monoclonality result.



# High-Throughput Cell Culture Analysis

## B-Cell Cluster Identification for Antibody Discovery

Single B cell screening method emerged as a more efficient way than the traditional hybridoma method in antibody discovery. It reduces turnaround time and enhances the possibility of identifying rare binders. However, it is challenging to distinguish B-cell clusters from MEF feeder cells, and manual inspection is required to identify wells with single B-cell cluster. Using AI-powered imaging processing algorithms, the Countstar Castor can accurately identify B-cell clusters in each well (shown below), allowing users to quickly verify the result. The area of the cluster is also measured over the culture duration, allowing the generation of growth curves.

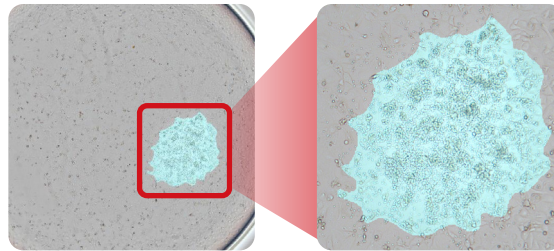

## iPSC-derived Embryoid Body Counting and Analysis

Embryoid bodies (EB) formation is a critical step in iPSCs-derived cell therapies. Because the size of EBs affects the differentiation rate, it is vital to monitor the size distribution of EBs to ensure batch reproducibility to meet GMP requirements. The Countstar Castor captures clear image of the EBs with varying sizes, automatically provides the number of EBs and diameters distribution in each well.

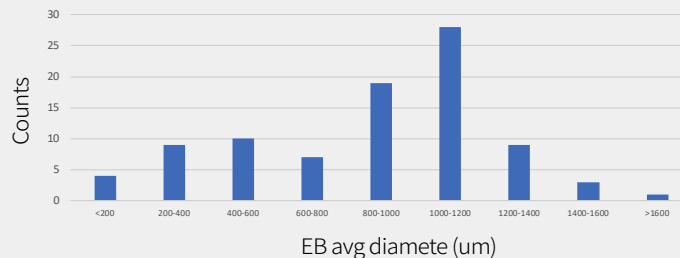
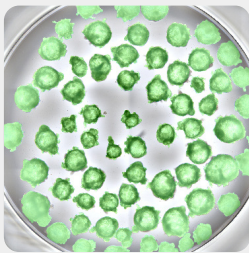

## Confluence Analysis

Lab grown meat holds promise to reduce environment impact of meat production and secure future supply. It is essential to identify a stable cell line with high proliferation property to reduce overall cost. Using Castor's label-free confluence analysis function, growth areas and clone formations in 96-well plates can be continuously monitored, classified, and quantified. The Countstar Castor provides the most advanced approach to identify promising clones with the optimum growth rate for downstream cell line optimization.

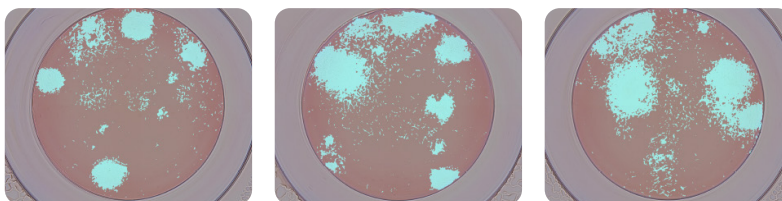

Images of muscle cells cultured in well D12(left), B11(middle), B8(right) on Day 6.

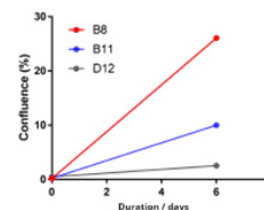

# High-Throughput Cell Culture Analysis

## Cell Concentration & Viability

Cell counting and viability analysis of cells in bright field (Trypan Blue) or using fluorescent dyes (e.g. AO/PI) are the most frequent routine operation in a cell culture lab. The Countstar Castor can automatically analyze samples on a 96-well plate, eliminate manual sample handling with traditional cell counting. It takes only 6 minutes to complete image acquisition with Trypan Blue staining, or 14 minutes with AO/PI staining. Besides cell count and viability, the Countstar Castor also provides additional information such like aggregation rate, cell diameter and cell morphology parameters.

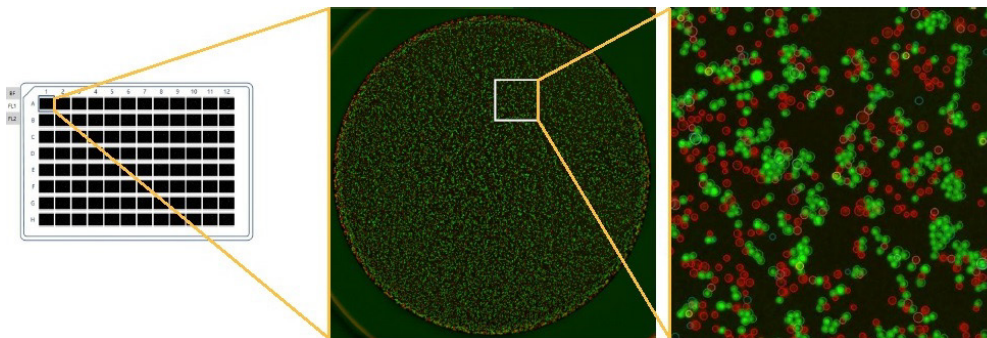

HEK 293 cells cultivated in 96-well plates over 9 days. Images show the cells in one well at day 7, stained by AO/PI. Green: viable cells; Red: dead cells

## Virus Plaque Assays

Past viral pandemics have shown how essential it is to quickly develop a target-specific vaccine to save lives. The Countstar Castor enables automated, high-throughput virus titer measurement using viral plaque assay or viral immune staining assay, significantly reduces the overall development time to identify the most-effective vaccine.

After the whole-well image is captured, the Countstar Castor quickly and accurately identify the plaques, including the small ones that can be easily missed with manual counting, and calculate the area of each identified plaque.

- The quantitative information allows the establishment of standard operation across users and sites, removes human bias in plaque characterization.
- The ability to accurately identify viral immunity blue or brown spots at single cell level greatly improves accuracy and reduces data processing time.

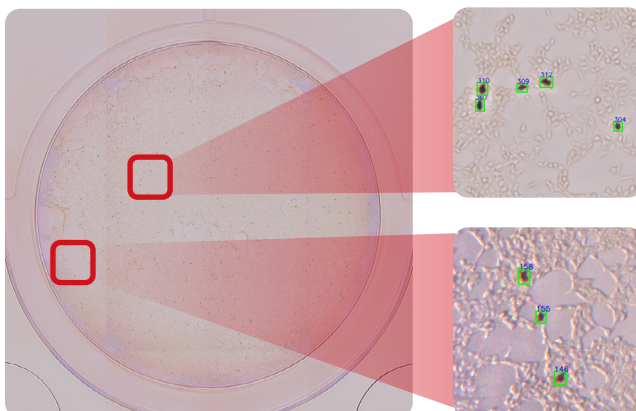

ID	Plaque Count	Ave. Diameter (mm)
A2_01	505	19.14
A3_01	8	23.00
B2_01	559	19.78
B3_01	492	19.88
C2_01	555	19.80
C3_01	544	20.49
D2_01	484	19.73
D3_01	528	19.49

# TECHNICAL SPECIFICATIONS

Light sources	High performance LEDs
Optical magnifications	4x objective lens (NA=0.2), 10x objective lens (NA=0.3)
Imaging element	16-bit, 10-megapixel, cooled CMOS color camera
Focusing mode	Laser ranging auto-focus
Allowed Consumables	6-384 well plates, microscope glass slides, culture dishes, cell culture T-flasks
Consumable load	1 multiwell plate / tray / t-flask / petri dish per analysis
Maximum path length of XY motorstage	X: 115mm Y: 220mm
Scope of Z-axis scanning	0-7.8mm
Fluorescence channels	Ex: 395/15nm EM: 460/20nm EX: 480/30nm EM: 535/40nm EX: 545/15nm EM: 590/25nm
Storage capacity	2TB SSD + 4TB HDD
Power input	AC110-240V、 50/60Hz、 1.5A
Monitor size	23in
Computer configuration	i7 processor, 64G RAM, 1650S NVIDIA 4GB graphics card, MS-Win 11 operating system
Computer dimensions (W*D*H)	6.7in×11.8in×14.5 in(169mm × 300mm × 367mm)
Analyzer dimensions (W*D*H)	21.8in×21.3in×19in(555mm × 540mm × 482mm)
System weight (Analyzer, CPU, and Monitor)	80.4lbs (36.5kg)



## Ordering Information

Model	Product Numbers
Countstar Castor X (2D)	P020400015
Countstar Castor S (3D Organoids)	P020400011
Countstar Castor Hybrid (X2+S2 software)	P020400012

**Contact:**  
ALIT Biotech (Shanghai) Co., Ltd., Europe  
ALIT LifeTech Inc., U.S.A.

[www.countstar.com](http://www.countstar.com)  
[marketing@countstar.com](mailto:marketing@countstar.com)